

MAKING YOUR FIRST SOVIET BELT

Guide written by Seth Byrnes

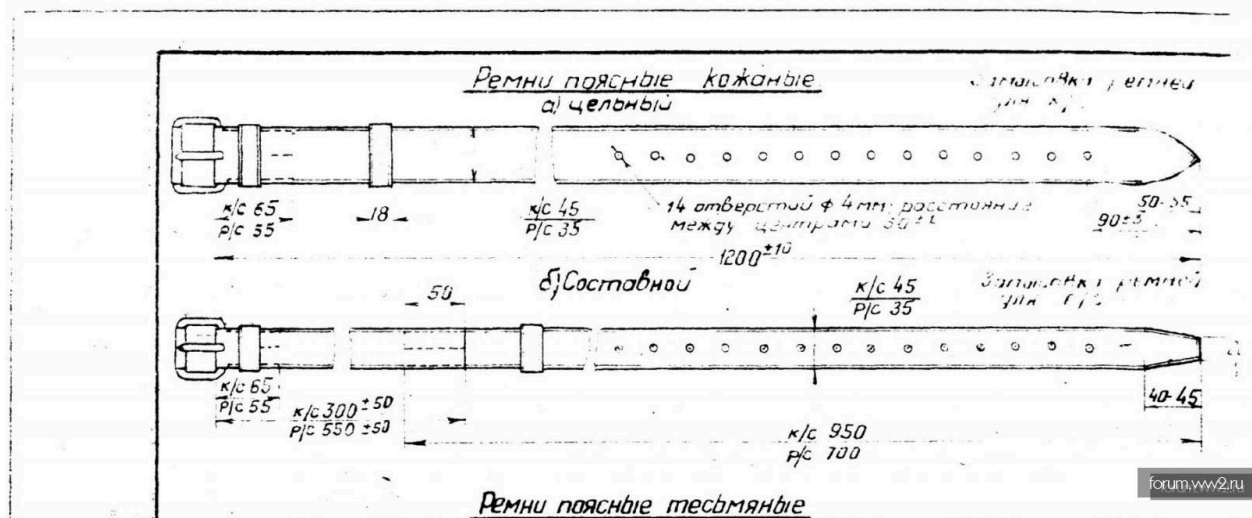

[In partnership with 191st Rifle Division](#)

Special thanks to member

Sergei Ereemeev

Additional thanks to

[Red Guard Militaria](#) for guidance and help locating source materials.
[Club Istochnik](#), without whom I would have no introduction to the 191st.

[MAKING YOUR FIRST SOVIET BELT](#)

[Preamble](#)

[Tools and Materials](#)

[Tools](#)

[Materials](#)

[Method](#)

[Procedure](#)

- [1. Cut your strap](#)
- [2. Measure and cut your tip](#)
- [3. Fold your tab](#)
- [4. Mark the pin for your hole](#)
- [5. Cut the pinhole](#)
- [6. Make your belt sliders](#)
- [7. Mark your stitches](#)
- [8. Knock your stitch holes](#)
- [9. Add your buckle](#)
- [10. Add your belt slider](#)
- [11. Stitch in your buckle](#)
- [12. Add the second slider](#)
- [13. Cut your adjustment holes](#)
- [14. Stamping](#)

[Interesting Supplementary Photos](#)

Preamble

A belt is one of the most fundamental items in a soldier's kit.

It defines whether they are on or off duty, and so I like to think that a belt both philosophically and physically defines how a soldier carries weight.

As such, it behooves you to ensure that you have a belt that, much like a soldier, looks and acts smart when it is required.

This guide, assembled in partnership with the 191st Rifle Division of Toronto, ON, will attempt to teach you how to fabricate your own belt.

Tools and Materials

Tools

Needles - I recommend 'John James' brand Saddlers Harness needles, L3912



Strap Cutter - It does not matter what type, I personally use an \$18 imitation of a C.S. Osborne draw gauge.



Knife - You may use an X-acto / Olfa or craft knife, or be a traditionalist and use a round knife. Used to trim edges, cut your point, and make the hole for the pin of your buckle.



Hole Puncher - Technically optional but I would highly recommend it. Used to make a clean hole for your buckle pin, and holes for your adjustment.

CAVEAT: Do NOT spend \$30 on a flimsy modern hole punch by accident - this tool can last your entire life if you spend \$50 on a quality modern model, or less on a used vintage model.



Optional:

Stitch Groover - Used to make a slight bevel at the edges of the belt.

Purely aesthetic, therefore optional.



Spring Clamps or Binder Clips - these are great for freeing up your hand to do work, and also for molding leather. Necessary if you're going to shame history and use glue.



Materials

Thread -You want thick 3+ cord linen thread. If you're going to make many belts, just buy a large cone of french linen and you'll have enough for buttons for a long time, too.

Leather - 6-8Oz leather of 120cm width.

Picking leather is a bit tricky, as ideally you want the grain to run in the correct direction so you can avoid a stretchy belt.

Double shoulders are a good choice, and I would recommend bovine or water buffalo leather. Veg tan is the best possible choice but you could still make a great belt with some oil tanned leather.



Buckle -You want steel or stainless steel heel bar roller buckles in approximately 35-40mm in width. I have seen a variety of shapes and sizes, and I feel anything inside this category is fine so long as it has straight edges (no swooping dress belt buckles). The highest quality buckles will have thick reinforcements on either side of the pin, and a thick pin.



Optional :

Stamps + Ink - Denis Kuparinen sells reproductions of sewing factory stamps for \$25. For ink, I recommend StazOn solvent ink from Japan as it is indestructible to almost anything but alcohol and can also be used to mark metal equipment.

Method

Procedure

1. Cut your strap

Using your strap cutter, cut a strip of leather 120 cm long and 38–40 mm wide (depending on your buckle width). Cut slowly, rushing this step is the point you are most likely to cut yourself or spoil your most valuable materials - the rest is easy.

Make sure the grain runs the same direction as the belt length to maximize strength. Confirm edges are straight and uniform along the entire length, trim up any issues with your knife.

Cut each end square.

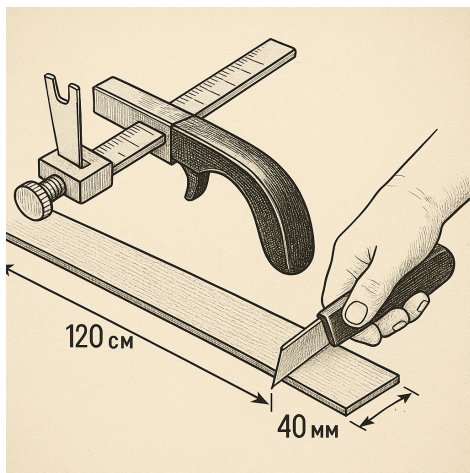

2. Measure and cut your tip

You want a blunt tip of approximately 2cm and a taper of 1cm that is 5cm long.

At the opposite end from your new tab, mark the center point (2cm, on a 40mm belt).

Mark 1cm on either side of your center point. Mark the strap 5cm up from your centerpoint on the strap at either edge.

Draw a line from your center point to either of your 1cm marks, then from your 1cm mark to your 5 CM mark.

You should now see the desired chisel tip shape marked on your belt.

Cut out your chisel point using a knife and straightedge.

Alternatively, you may use belt tip punch to create an english point but chisel tips appear to have been common enough, and require no special tools.

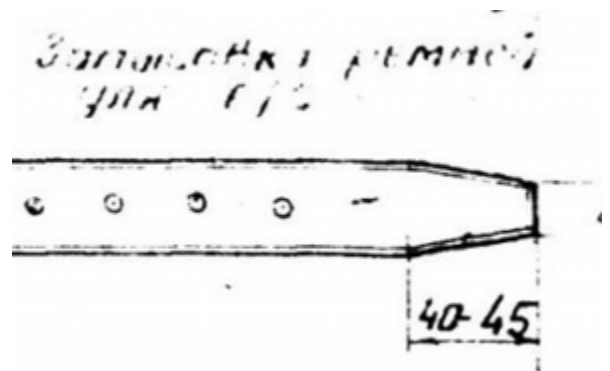
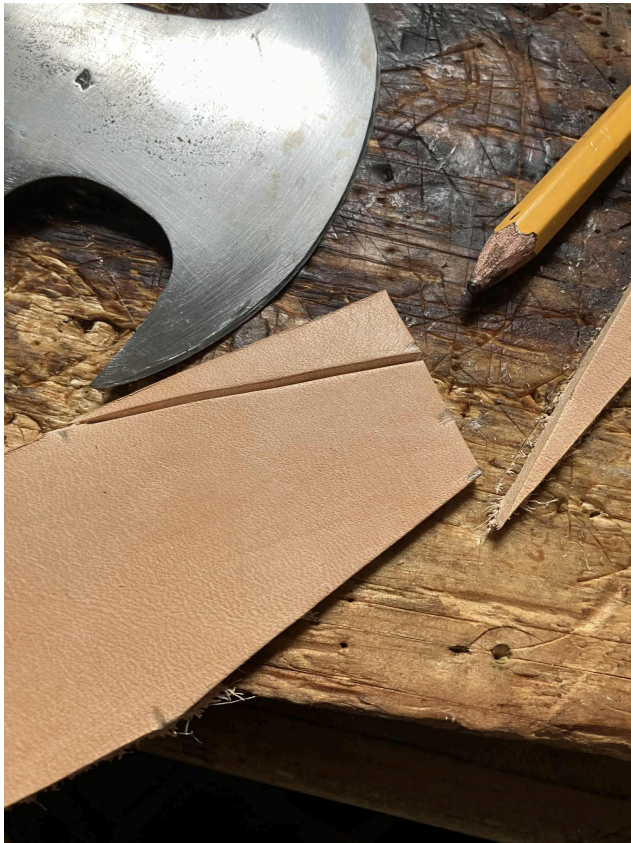

3. Fold your tab

At the opposite end of the strap, measure and mark 5 cm from the end—this will become the fold-over tab that holds your buckle.

Skive the flesh side lightly with a knife, or sand it on a belt sander or manually with a sanding block to reduce bulk when folded. Wet the tab in warm water, fold over and clamp it or set it under a weight to crease, or gently planish with a hammer.

Clean the tip with sandpaper if necessary.

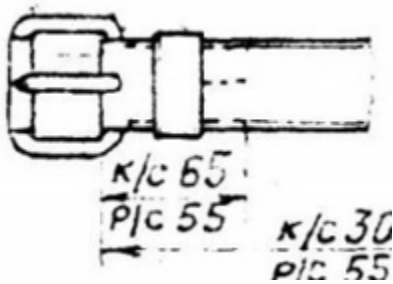
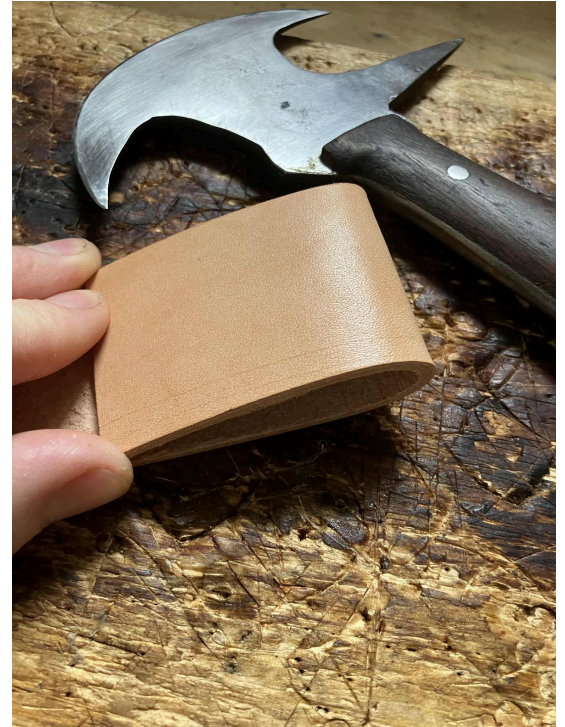

4. Mark the pin for your hole

Unfold the tab and center your buckle's pin over the midpoint of the crease.

Push down to mark the leather.

This will be your pin hole location.

Fold the belt tab and mark 1cm back from your indent.

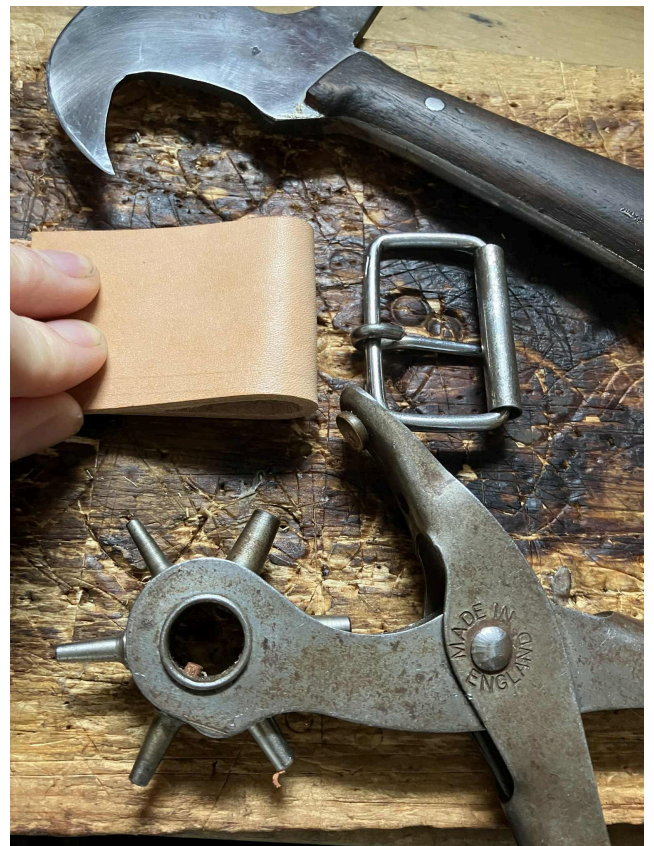

5. Cut the pinhole

Using your leather punch, punch a hole through both layers of your strap and tab at your 1cm mark. Using a knife, cut the rectangle for your pin from the hole to the fold in the tab.



6. Make your belt sliders

From your offcuts, cut two leather loops approximately 10 mm wide and long enough to snugly fit around your belt's width (usually ~70–75 mm before stitching).

These will secure the very long and loose end of the belt after it passes through the buckle.

You need two per belt, even though one will inevitably be lost by the user.

Punch three holes at either end and stitch the loops, wet them, and then clamp or weigh them with the seam in the center of the back while you continue to work.

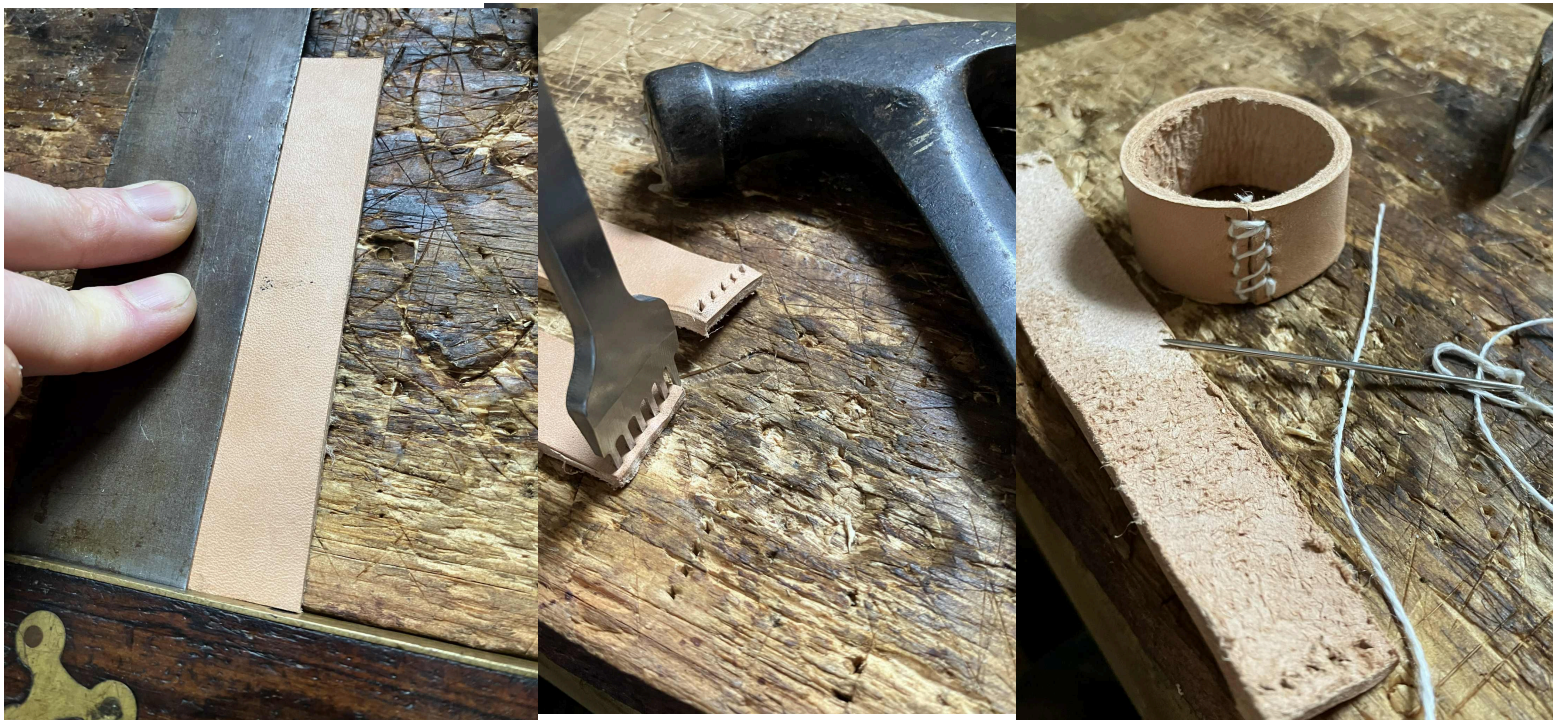

7. Mark your stitches

Assess your belt tab and get your stitching iron and set three lines of stitches.

You want ~18 stitches on either side, and a center row of the same number offset by 1cm from the rest.

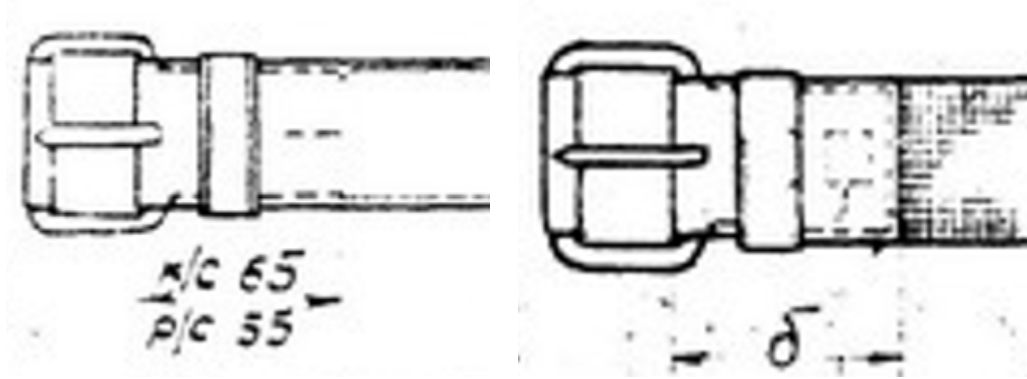

8. Knock your stitch holes

When you are happy with your marked placement, take your stitching iron and set your belt on a disposable wood surface. Pound your stitchholes.

Repeat on your tab. The center line will invariably move past the end of your tab - this is desirable.

9. Add your buckle

Place your buckle into the folded tab.

Pass the leather tab over the pin and heel bar, making sure the pin seats comfortably in the pin hole you punched earlier.

If it does not, now is the time to make adjustments using your knife. When the pin can move freely without obstruction but doesn't dangle in the wind, your hole is correct.

You may choose to make a concession to modernity and reinforce the area with glue. If you do, you may add it after you have put your first belt slider on.

This is a completely optional and hidden reinforcement, but take care not to use too much or it will be apparent. Make sure you gently clamp the fold while the glue sets up and do not proceed until fully dry. I scorned history in this example.



10. Add your belt slider

Slide one of your prepared loops onto the belt and position it directly behind where the buckle will be sewn. This loop should sit snug against the buckle when finished.

Fold the tab back over, and clamp securely.

11. Stitch in your buckle

Using a [saddle stitch technique](#), stitch the three lines you punched into the folded tab, locking the buckle and slider in place. This is the most rewarding part to see come together, take your time and crank each stitch as tight as you dare without breaking your thread.

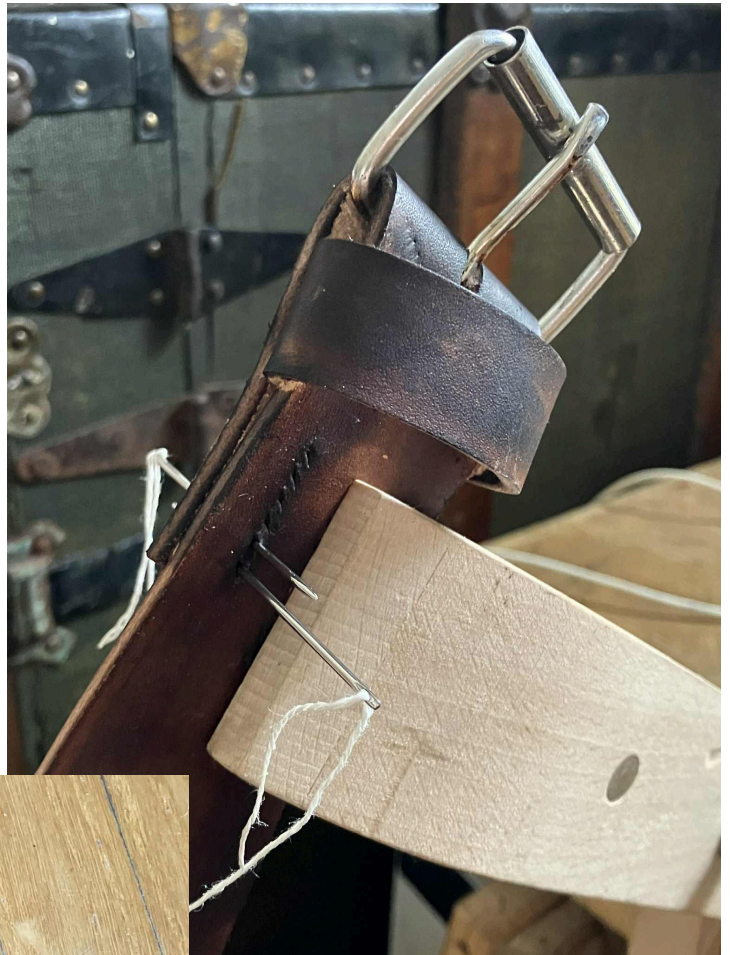

Really take your time with this step if it's your first attempt - stitching will really make or break the appearance of your belt.

When done, hit it with some additional beeswax on both the top and bottom.

12. Add the second slider

With your buckle secure, slot your second slider / keeper onto the strap.
This one stays loose, and this is why your end user will surely lose it.

C'est la vie / Таковажизнь.

I personally like the solution of a canteen hanger as they are harder to lose than the original keeper and they have a secondary use. You also see them used thusly in original photos.

13. Cut your adjustment holes

Starting 10 cm from the tip, mark fourteen holes spaced 2.5 cm apart.

Use your round punch to cut each one cleanly.

Take care to keep the holes centered and consistent - it is very obvious when the holes are off center.



14. Stamping

If stamping, now is the time: dampen the end tab area lightly and press your factory mark firmly using even pressure.

Satisfaction is yours!

Some belts have only an OTK stamp near the tab, others may have a factory marking somewhere else on the strap. Yet others have nothing at all. I mark my belts with my initials because people tend to just walk off with an unattended pretty belt - trust me.





Ремень поясной кожаный

а) цельный

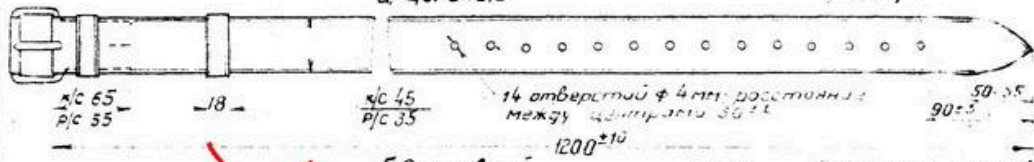

б) составной

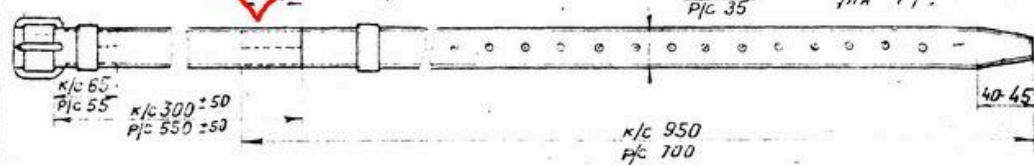

Ремень поясной текстильный

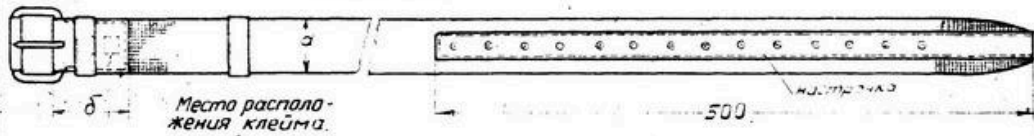

Размеры	а	б	в
Ремень к/с	45 ^{±3}	65	25
Ремень р/с	35 ^{±3}	55	20

Ремень поясной р/с брезентовый

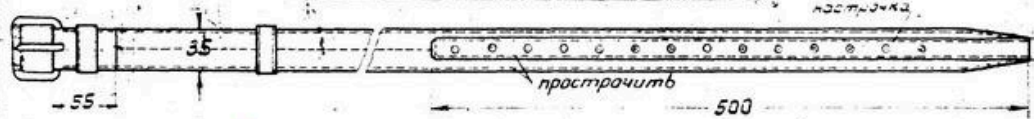

Ремень поясной р/с кожаной састрочной

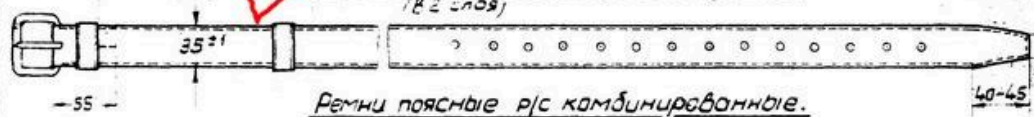

Ремень поясной р/с комбинированный.

а) с цельным гортом (показан текстильно-кожаный)

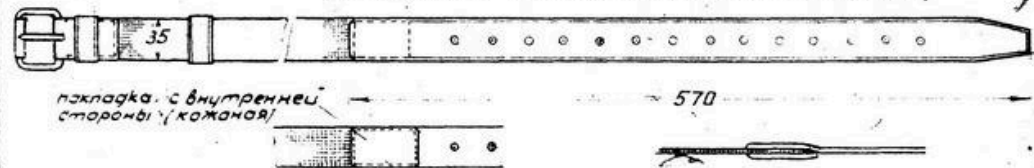

б) с састрочным гортом (показан брезентово-кожаный)

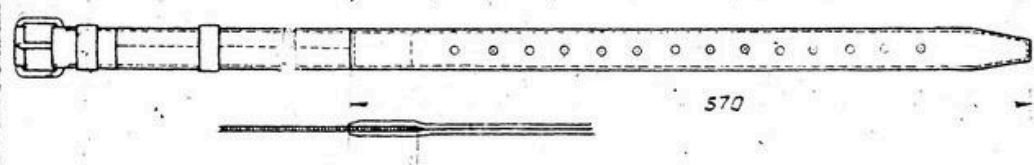

Interesting Supplementary Photos

Spliced Belt (Seen in the specs but not often in pics)

Shortened Belt

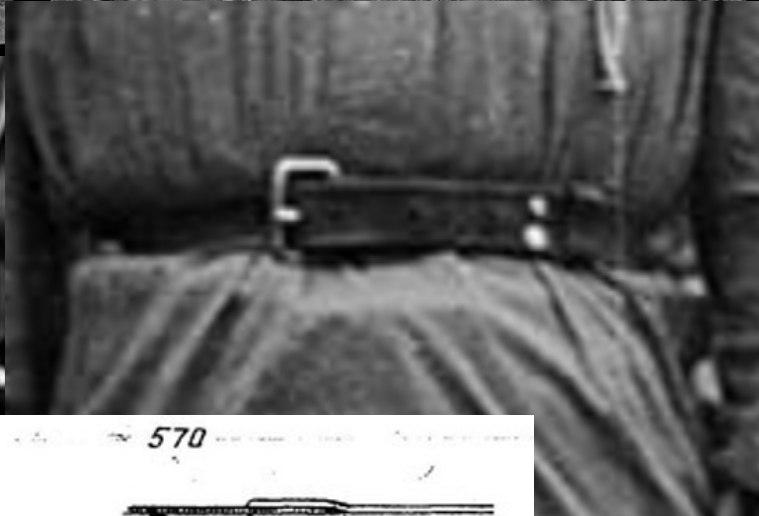

пояска с внутренней стороны (кожаная)

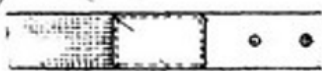

с сострочным гортом (показан брезентово-кожаный)

Lend lease belt / Grommets added to belt



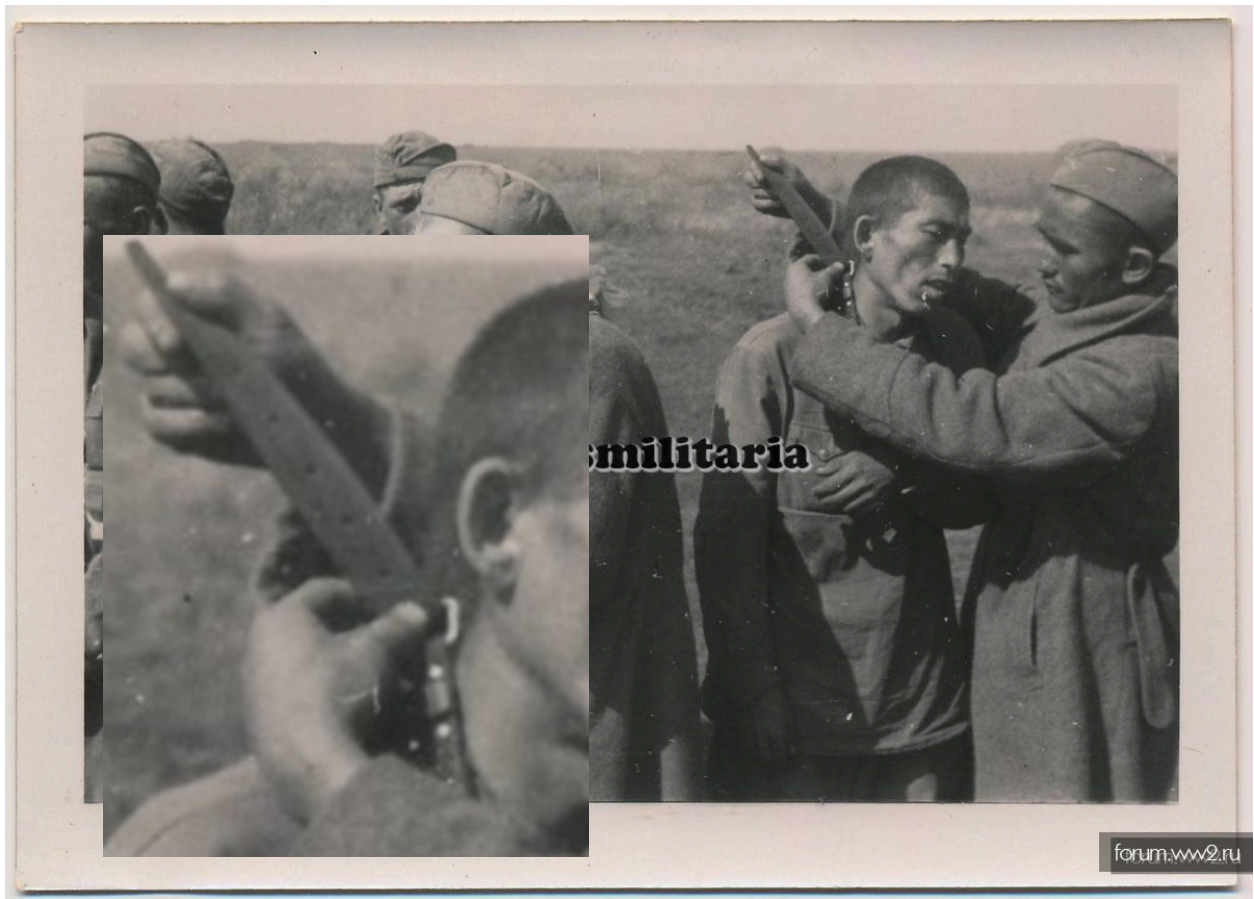

4-Rivet belt being used as a sling / Original 4 rivet belts





Canteen hanger as belt keeper

Double holes punched or converted belt with a single pin roller buckle



Original stamps on a belt tab





Comparison between two variants of belts.

Machine Stitched belt variant



Belt Splice made with Rivets



forum.ww2.ru



forum.ww2.ru

A couple image source links:

[Поясные ремни Красноармейца - Страница 3 - СССР - Форум Военно-Исторических Реконструкторов](#)

[Ремень на заклепках на определение. РККА? - Снаряжение. обмундирование. регалии - Форум и аукцион военной истории — WW2](#)

Both these RU language forums have many other useful threads for research.

<https://ww2abc.com/collections/the-forgotten-archive-of-czech-amateur-photographer-Peska>

Some of the other images come from the Arthur Bondar collection, also worth visiting.

Unrelated but still useful:

[Soviet WW2 Boots // Реконструкция начинается с обуви. Часть 2: сапоги РККА | VK](#)

[Evolution of Soviet rifle pouches – notes of soviet armorer](#)

A couple of articles that have been extremely useful to building my own impression.

Shout out to Denis Stepanov, who shared both with me.